

# HT-Breeze Instantaneous Water Heaters



Breeze  
extended to  
include Variable  
Speed Drives

Breeze range  
extended to include  
Steam Primary

# Contents



## HT-Breeze

pages 2-7

When space is tight and hot water needs to be carefully controlled, that's when the new HT-Breeze range of plate heat exchangers comes into its own. Thirteen outputs, 0.25 to 5.00 litres/second, all on the same compact 340mm x 750mm footprint.

New standard features mean the new HT-Breeze gives even better control of hot water generation. Added to the time, temperature and pump control setting, the new Breeze offers:

- Automatic night set-back plus an anti-legionella pasteurisation cycle.
- Remote operating temperature display.
- Remote adjustment of set points.
- Full BMS compatibility.
- 3 or 4 port valve operation.

Installed 'stand alone', or with a buffer vessel, the new HT-Breeze can provide flexible hot water generation for large and small projects, whether new or retrofit.



## Vari-E-Breeze

pages 8-11

Plate heat exchangers provide a fast reacting and variable response to hot water demands, especially when those demands can change in seconds from, say, a single tap to a multiple shower operation.

The new Vari-E-breeze combines our plate exchanger expertise with the variable speed technology of the Grundfos MAGNA pump, giving closer control of output, greater speed of response and therefore, enhanced energy efficiency and lower running costs.

The new Vari-E-breeze range is available in outputs from 0.25 l/sec to 4.0 l/sec. In addition to the time, temperature and pump control setting, the standard Breeze controller offers an automatic night set-back plus an anti-legionella pasteurisation cycle, retransmission of water temperature, remote set point adjustment and BMS compatibility, with single or twin head variable speed pump.

## Steam-Breeze

pages 12-15



Connecting into an existing steam main to provide heating or hot water is made easier and quicker with the introduction of Rycroft's new Steam-Breeze. The stainless steel plate exchanger package can make the interface of steam to DHW or LTHW applications simpler.

The standard range of units provides for heat loads of up to 1.1MW, which in DHW service will provide a 5 l/sec flow. Larger loads can be accommodated by using Rycroft's bespoke design and build capability.

Control of the primary side of the Steam-Breeze can be by electric or pneumatic valves, selected to provide accurate temperature control. Also included are isolation, anti-vacuum valves and line

strainer. High limit protection is provided as a standard feature on this range. A standard float trap system is incorporated into the condensate side, and an advanced three term (PID) controller within the panel provides secondary temperature control.

The standard units can be extended to incorporate additional equipment such as secondary pumps, buffer storage, pressure reducing sets and specific valve arrangements, all controlled through the central panel.

The Steam-Breeze has a relatively small footprint and is simple to install, requiring only the connection of electrical power or air, steam inlet and condensate outlet, with flow and return connections on the secondary side.

Breeze units are also available for low and medium temperature hot water applications with fixed valve and pump control or with variable pump (Vari-E-Breeze).

# HT-Breeze Instantaneous Water Heaters

THE HT-BREEZE INSTANTANEOUS WATER HEATER PROVIDES AN ECONOMIC AND EASY TO USE SOLUTION FOR PROVIDING HOT WATER. WHEN THE PACKAGE IS INSTALLED AND SWITCHED ON, THE SIMPLE TO USE CONTROLLER WILL RUN THE APPROPRIATE NUMBER OF PUMPS AND CONTROL AT 60°C. THE FACTORY DEFAULT SETTINGS WILL SUIT 95% OF APPLICATIONS WITHOUT FURTHER ADJUSTMENT. THESE DEFAULT SETTINGS ARE FREELY ADJUSTABLE AND ARE AS FOLLOWS.

## Default Settings

- 24-Hour Operation.
- Set Temperature.
- Time Display.
- Number of pumps fitted.
- Auto pump changeover on a timed basis.
- High temperature cut out (manual reset).
- Low temperature alarm.
- PID settings.
- Pump run on times.

## Additional Settings

- Seven day calendar (two timed periods per day).
- Boost facility to activate the heater when in an OFF timed period.
- Low temperature boost facility.
- Actuator output curve and speed adjustment.
- Night setback and pasteurisation feature.

## Benefits

- Ideal for retrofit applications where access is limited or upgrading of existing calorifiers is required.
- Hot water produced as required.
- Reduce the risk from legionnaires disease by reducing the hot water storage requirements.
- Very compact design utilising the benefits of plate heat exchangers.
- Building Management System compatibility.
- Small area required for servicing.
- Negligible standing losses.
- Quick heat up and rapid response.
- Can be designed to be extended for future changes in demand.
- Vented and unvented applications.
- Complete packaged unit ready for immediate use.
- Electrically self protecting pumps.

## Combined Space/Water Heating Systems

Where the peak demand exceeds the available boiler power for water heating, installation techniques may resolve the problem. For example on a primary circuit, the HT-Breeze must be the first piece of equipment to be fed from the boiler. Under peak demand conditions, the boiler power can be directed to the HT-Breeze at the expense of the space heating demand.

Generally for installations where the boiler capacity is insufficient to meet the demand, a buffer vessel is connected in parallel with the HT-Breeze.

Rycroft have developed a range of buffer vessels specifically designed to match the HT-Breeze. Both vented and unvented options are available and can be skid mounted to provide a complete hot water package.

## Controller Features

- Large, clearly visible display of day, time, temperature and status.
- Process variable re-transmission.
- Remote set point adjustment.
- Remote enable/disable.
- Volt free change over fault contact.
- Displayed alarm messages.
- Runs to default settings on start up.
- Bar graph valve output indication.
- Three term modulating control (PID).
- Time boost facility.
- Dual primary pump (duty/standby plus auto change over) shunt and secondary re-circulation pump control.

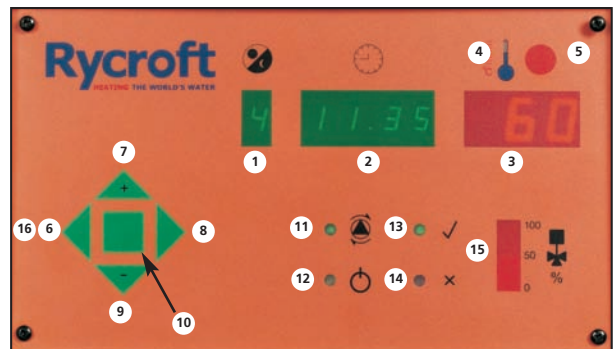

- |                                     |                              |                                |
|-------------------------------------|------------------------------|--------------------------------|
| 1. Day/Mode Display                 | 7. Value Increase Pushbutton | 13. System Healthy Indicator   |
| 2. Time/Alarm Display               | 8. Step Right Pushbutton     | 14. System Fault Indicator     |
| 3. Temperature/Parameter Display    | 9. Value Decrease Pushbutton | 15. Valve Position Bar Display |
| 4. High Temperature Alarm Indicator | 10. Mode Select Pushbutton   | 16. On/Off Switch              |
| 5. Reset Pushbutton                 | 11. Pump Energised Indicator |                                |
| 6. Step Left Pushbutton             | 12. Power On Indicator       |                                |

# Operation

The HT-Breeze comprises of a Supapac Plate Heat Exchanger, either a 3-port or 4-port control valve, primary pump, temperature sensor and PID controller all mounted on a skid base.

The motorised 3 or 4 port control valve allows rapid adjustment of the primary heat input to match changes in secondary hot water demand.

The HT-Breeze requires no insulation and the design ensures that the outlet temperature does not fall below the set point (60°C default but can be adjusted to suit customer requirements) and consequently reduces the risk of legionnaires disease.

Providing the class of accommodation and details of the number and type of fixtures are known, Rycroft will be pleased to recommend the optimum size of HT-Breeze.

## Schematic Diagram

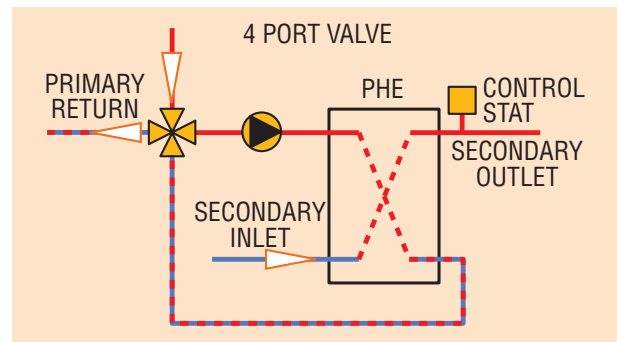
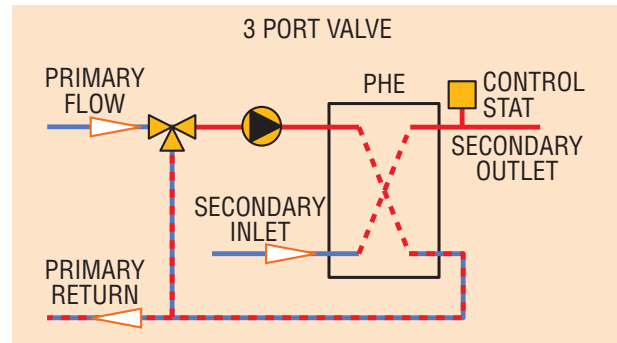

## Typical Schematic for Unvented HT-Breeze/Buffer Application

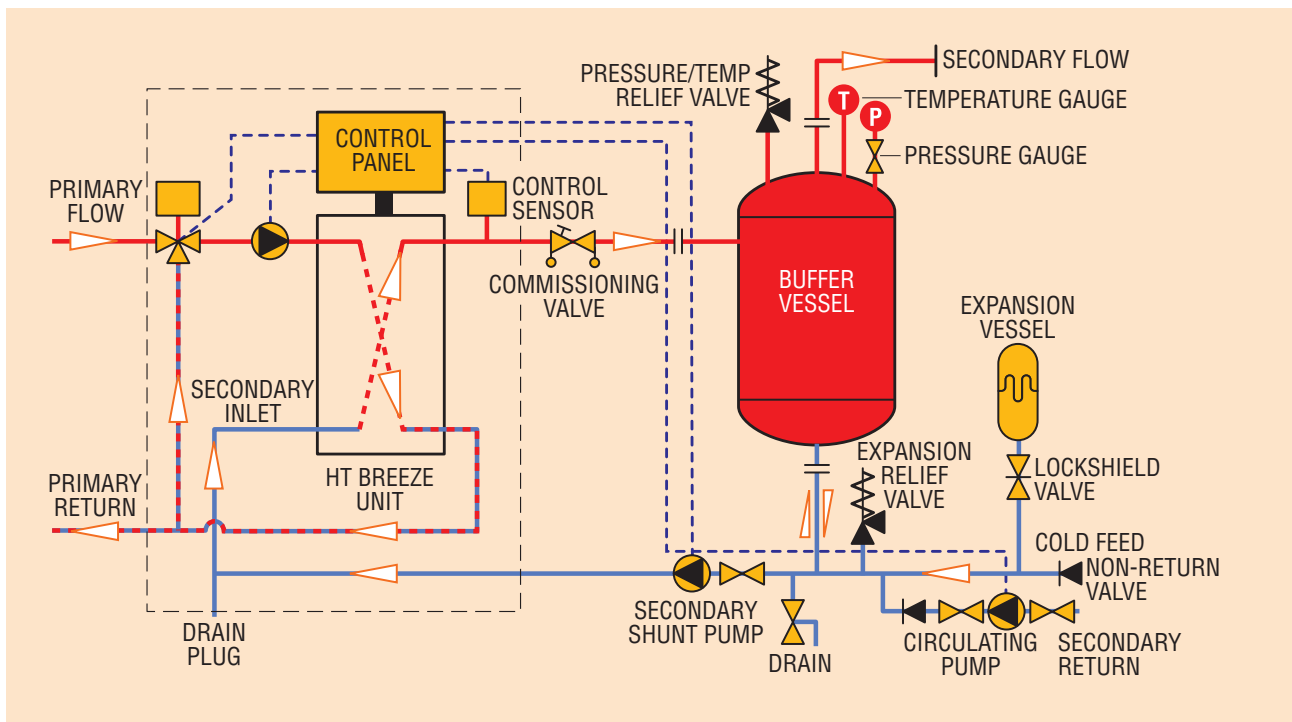

# Sizing and Selection of a Stand Alone HT-Breeze

To size the HT-Breeze use the following demand factors:

| Facility                   | Private Hand Basin | Public Hand Basin | Shower | Bath | Slop Sink | Bar Sink | Kitchen Sink | Washing Machine | Laboratory Sink | Dish Washer |
|----------------------------|--------------------|-------------------|--------|------|-----------|----------|--------------|-----------------|-----------------|-------------|
| Hospital                   | 1                  | 2                 | 4      | 4    | 4         |          | 10           | 10              | 3               | 10          |
| Hotel and Residential Hall | 1                  | 2                 | 4      | 4    | 4         | 12       | 10           | 10              |                 | 10          |
| School                     | 0.5                | 3                 | 10     | –    | 3         |          | 10           | 3               | 3               | 10          |
| Sports Centre/ Barracks    | 0.5                | 2                 | 10     | –    | 3         | 12       | 10           | –               | –               | 10          |
| Restaurant                 | 0.5                | 4                 | –      | –    | 12        | 12       | 19           | –               | –               | 10          |
| University                 | 0.5                | 3                 | 10     | –    | 3         | –        | 10           | –               | 3               | 10          |
| Offices                    | 0.5                | 3                 | 3      | –    | 3         | –        | 10           | –               | 3               | 10          |
| Factory                    | 0.5                | 3                 | 4      | –    | 3         | –        | 10           | –               | 3               | 10          |
| Apartments                 | 1                  | –                 | 4      | 4    | 3         | –        | 3            | 3               | –               | 2           |

## Sizing Considerations

Careful consideration must be given to the sizing of stand alone instantaneous water heaters. Standard demand units incorporate a degree of diversification that would be inappropriate for continuous use applications. For continuous applications a more desirable method of sizing is to complete a fixture count and allocate an appropriate flow for each fitting. It should also be noted that shower demands for schools, sports centres and universities should only be used for medium to large installations. Please refer to our design department for further information.

The minimum secondary circuit volume for a stand alone HT-Breeze should not be less than the figures shown in the sizing table on this page.

This is to prevent nuisance high limit trips, which could occur if the secondary volume is not enough to keep the plate heat exchanger cool whilst the control valve closes when there is no demand for hot water.

It is recommended that a secondary return line should always be used with the HT-Breeze for the same reason.

## Example

Using the above table for a 173 bed hospital ward with showers, hand basins and sinks.

42 Single Person Showers = 42 x 4 = 168

55 Private Hand Basins = 55 x 1 = 55

9 Public Hand Basins = 9 x 2 = 18

3 Slop Sinks = 3 x 4 = 12

15 Baths = 15 x 4 = 60

Total Demand Units = 313

The shower factors are based upon intermittent use. Where certain activities may result in all showers operating together please contact our sales department for advice.

The correctly sized HT-Breeze can now be selected from the sizing table below. In this example a CP-B250 should be selected.

## Sizing Table

| HT-Breeze Model | Maximum Demand Unit | Max Continuous Duty @ 60°C (litres/sec) | Boiler Power (kw) | Min Secondary Volume (litres) |
|-----------------|---------------------|---|-------------------|-------------------------------|
| CP-B25          | 15                  | 0.25                                    | 52                | 45                            |
| CP-B50          | 23                  | 0.50                                    | 105               | 75                            |
| CP-B75          | 45                  | 0.75                                    | 157               | 85                            |
| CP-B100         | 70                  | 1.00                                    | 209               | 125                           |
| CP-B125         | 90                  | 1.25                                    | 261               | 135                           |
| CP-B150         | 130                 | 1.50                                    | 313               | 150                           |
| CP-B200         | 210                 | 2.00                                    | 418               | 200                           |
| CP-B250         | 320                 | 2.50                                    | 522               | 250                           |
| CP-B300         | 480                 | 3.00                                    | 627               | 300                           |
| CP-B350         | 640                 | 3.50                                    | 732               | 350                           |
| CP-B400         | 820                 | 4.00                                    | 836               | 400                           |
| CP-B450         | 1050                | 4.50                                    | 935               | 450                           |
| CP-B500         | 1300                | 5.00                                    | 1040              | 500                           |

# Sizing and Selection of a HT-Breeze and Buffer Vessel

To size the HT-Breeze use the following demand factors:

| Facility                   | Private Hand Basin | Public Hand Basin | Shower | Bath | Slop Sink | Bar Sink | Kitchen Sink | Washing Machine | Lab Sink | Dish Washer | Load Factor |
|----------------------------|--------------------|-------------------|--------|------|-----------|----------|--------------|-----------------|----------|-------------|-------------|
| Hospital                   | 10                 | 15                | 70     | 60   | 50        | –        | 80           | 100             | 40       | 150         | 0.7         |
| Hotel and Residential Hall | 10                 | 15                | 50     | 50   | 50        | 100      | 80           | 100             | –        | 150         | 0.5         |
| School                     | 5                  | 20                | 180    | –    | 40        | –        | 80           | 40              | 40       | 150         | 0.8         |
| Sports Centre/ Barracks    | 5                  | 15                | 220    | –    | 40        | 100      | 80           | –               | –        | 100         | 1           |
| Restaurant                 | 5                  | 25                | –      | –    | 100       | 100      | 140          | –               | –        | 150         | 1           |
| University                 | 5                  | 20                | 220    | –    | 40        | –        | 80           | –               | 40       | 150         | 0.8         |
| Offices                    | 5                  | 10                | 180    | –    | 40        | –        | 40           | –               | 40       | 100         | 1           |
| Factory                    | 5                  | 20                | 120    | –    | 50        | –        | 80           | –               | 40       | 100         | 1           |
| Apartments                 | 5                  | –                 | 50     | 50   | 40        | –        | 20           | 40              | –        | 20          | 0.7         |

## Example

Using the above table for a 173 bed hospital ward with showers, hand basins and sinks.

|                              |   |            |   |           |
|------------------------------|---|------------|---|-----------|
| 42 Single Person Showers     | = | 42 x 70    | = | 2940      |
| 55 Private Hand Basins       | = | 55 x 10    | = | 550       |
| 9 Public Hand Basins         | = | 9 x 15     | = | 135       |
| 3 Slop Sinks                 | = | 3 x 50     | = | 150       |
| 15 Baths                     | = | 15 x 60    | = | 900       |
| Total Volume                 | = |            | = | 4675      |
| Load Factor from above table | = |            | = | 0.7       |
| TOTAL DEMAND RATE            | = | 4675 x 0.7 | = | 3273      |
|                              |   |            |   | litres/hr |

The HT-Breeze and buffer vessel combination should be sized as follows:

The buffer vessel capacity should be 25% of the hourly demand.  
 Therefore the required storage capacity = 3273 x 0.25 = 818 litres. The nearest standard buffer vessels sizes are 800 and 900 litres. It is recommended to go up in sizes, therefore use a 900 litre buffer.

The HT-Breeze can be selected as follows:

The continuous hourly demand = 3273 litre.  
 $Kw = \text{flow (l/s)} \times \text{specific heat of water} \times \text{temp difference (}^\circ\text{C)}$   
 Therefore the required kW rating =  $\frac{3273}{3600} \times 4.187 \times (60-10)$   
 = 190.3 kW

Using the sizing table on the previous page.

The nearest standard HT-Breeze = CP-B100 rated at 209

The sizes shown in the sizing table represent the standard range of HT-Breeze units. These are available with both single head and dual head primary pumps. The following pages describe the full range of models available.

Standard buffer vessels are available in the following sizes:

|         |          |          |          |
|---------|----------|----------|----------|
| 440 ltr | 800 ltr  | 1200 ltr | 1800 ltr |
| 550 ltr | 900 ltr  | 1350 ltr | 2000 ltr |
| 700 ltr | 1000 ltr | 1500 ltr | 2300 ltr |

For larger capacities please refer to the Storage Calorifier catalogue

A HT-Breeze and buffer vessel is used when water demand is not constant but high flow rates occur frequently. Storing hot water in the buffer vessel for peak demands reduces boiler power.

When enquiring please specify the required working or design pressure of the system to enable Rycroft to optimise the copper cylinder thickness to suit your requirements. Both Vented and Unvented packages are available. Please contact our technical department for further assistance.





# HT-Breeze fitted with Dual Head Pump

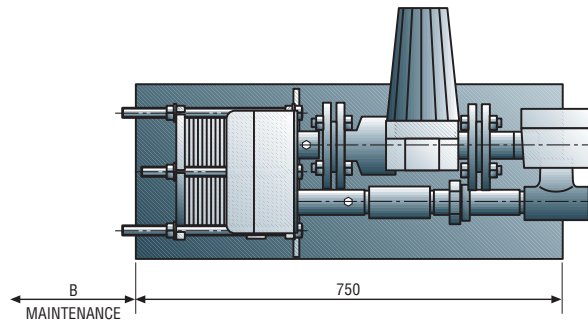
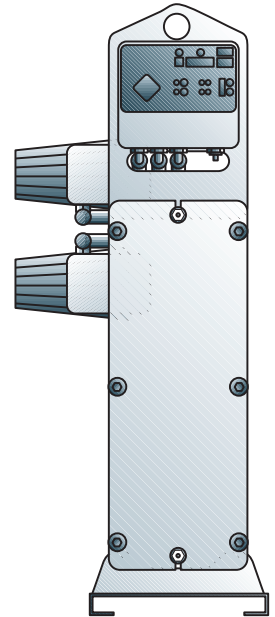
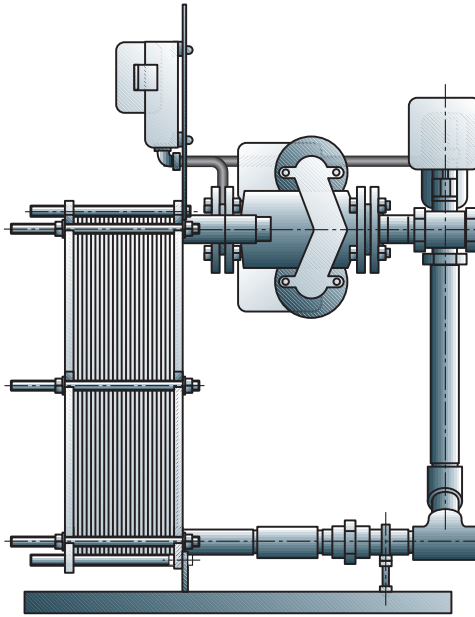
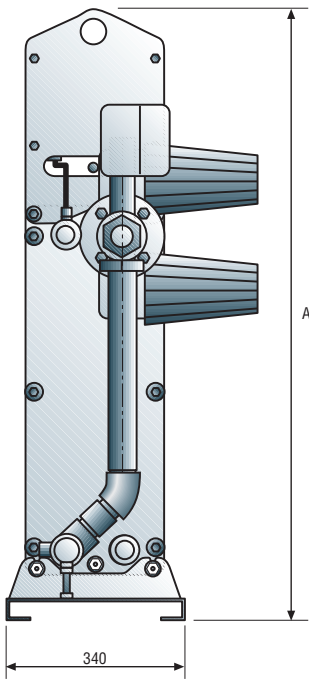

## Materials

- DHW wetted parts – Stainless Steel
- Frame – Powder Coated Carbon Steel
- Controller – Polycarbonate Enclosure

## Supply

- 230 Volts, single phase
- 400 Volts, three phase

## Dimensions

- |                    |   |   |
|--------------------|---|---|
|                    | A | B |
| CP-B25 to CP-B250  |   |   |
| 1115               |   |   |
| 450                |   |   |
| CP-B300 to CP-B500 |   |   |
| 1240               |   |   |
| 550                |   |   |

## 3-way Valve

- |                       |             |
|-----------------------|-------------|
| Primary Temperature   | – 120°C Max |
| Primary Pressure      | – 10 Barg   |
| Secondary Temperature | – 90°C Max  |
| Secondary Pressure    | – 10 Barg   |

## 4-way Valve

- |                       |             |
|-----------------------|-------------|
| Primary Temperature   | – 120°C Max |
| Primary Pressure      | – 6 Barg    |
| Secondary Temperature | – 90°C Max  |
| Secondary Pressure    | – 6 Barg    |

# HT-Breeze – Available Models

| Model Number | A<br>230 Volts<br>1 phase Supply<br>Fused Protection<br>3 Way Valve | B<br>230 Volts<br>1 phase Supply<br>Fused Protection<br>4 Way Valve | C<br>230 Volts<br>1 phase Supply<br>O/Load protection<br>3 Way Valve | D<br>230 Volts<br>1 phase Supply<br>O/Load protection<br>4 Way Valve | E<br>415 Volts<br>3 phase Supply<br>O/Load protection<br>3 Way Valve | F<br>415 Volts<br>3 phase Supply<br>O/Load protection<br>4 Way Valve |
|--------------|---|---|--|--|--|--|
| CP-B25       | ✓   | ✓   | ✓  | ✓  | ✓  | ✓  |
| CP-B50       | ✓   | ✓   | ✓  | ✓  | ✓  | ✓  |
| CP-B75       | ✓   | ✓   | ✓  | ✓  | ✓  | ✓  |
| CP-B100      | ✓   | ✓   | ✓  | ✓  | ✓  | ✓  |
| CP-B125      | ✓   | ✓   | ✓  | ✓  | ✓  | ✓  |
| CP-B150      | ✓   | ✓   | ✓  | ✓  | ✓  | ✓  |
| CP-B200      | ✓   | ✓   | ✓  | ✓  | ✓  | ✓  |
| CP-B250      | ✓   | ✓   | ✓  | ✓  | ✓  | ✓  |
| CP-B300      | ✓   | ✓   | ✓  | ✓  | ✓  | ✓  |
| CP-B350      | ✓   | ✓   | ✓  | ✓  | ✓  | ✓  |
| CP-B400      | ✓   | ✓   | ✓  | ✓  | ✓  | ✓  |
| CP-B450      | ✗   | ✗   | ✓  | ✓  | ✓  | ✓  |
| CP-B500      | ✗   | ✗   | ✓  | ✓  | ✓  | ✓  |

All models are available with either single head or dual head primary pumps

The standard models have been designed to produce secondary water at 60°C from a cold feed of 10°C using a primary flow temperature of 82°C. Temperatures outside these parameters normally only require a modified plate pack arrangement and Rycroft would be pleased to design this to meet your requirements. Please contact our technical department for further assistance.

## Ordering Information

| Requirements   | Example   |
|--|-----------|
| Select the required model number using the sizing information  | CP-B100   |
| Determine the primary pump requirement<br>Single or Dual Head (S or D)   | D         |
| Determine the power supply, control valve type and method of pump protection and choose the option from the above table (A to F) | A         |
| Order using the assembled model number   | CP-B100DA |

ie: HT-Breeze fitted with a 230V single phase Dual Primary Pump protected via a 5A fuse and controlled using a 3 way valve and actuator. Producing 1 litre/sec of secondary hot water at 60°C utilising a cold feed temperature of 10°C and a primary flow temperature of 82°C.



# Vari-E-Breeze

THE NEW VARI-E-BREEZE COMBINES OUR PLATE EXCHANGER EXPERTISE WITH THE VARIABLE SPEED TECHNOLOGY OF THE GRUNDFOS MAGNA PUMP, GIVING CLOSER CONTROL OF OUTPUT, GREATER SPEED OF RESPONSE AND THEREFORE, ENHANCED ENERGY EFFICIENCY AND LOWER RUNNING COSTS.

THE NEW VARI-E-BREEZE RANGE IS AVAILABLE IN OUTPUTS FROM 0.25 L/SEC TO 4.0 L/SEC. IN ADDITION TO THE TIME, TEMPERATURE AND PUMP CONTROL SETTING, THE STANDARD BREEZE CONTROLLER OFFERS AN AUTOMATIC NIGHT SET-BACK PLUS AN ANTI-LEGIONELLA PASTEURISATION CYCLE, RETRANSMISSION OF WATER TEMPERATURE, REMOTE SET POINT ADJUSTMENT AND BMS COMPATIBILITY, WITH SINGLE OR TWIN HEAD VARIABLE SPEED PUMP.

## The following additional benefits:-

- Unit only runs on demand
- Greater speed of response
- Lower running costs
- On pump status display
- Self protection built in to the pumps
- Closer control of output
- Enhanced energy efficiency
- Inherent soft start of primary pumps
- Longer pump life



The Vari-E-Breeze controller measures the temperature in the secondary pipework (using a sensor in the flow)

As the demand on the system increases, the pump speed is increased to match the demand and maintain the desired temperature.

A valve and actuator fitted in the primary circuit adds to the control accuracy and prevents any thermal creep.

As demand approaches zero the control system shuts down the pump. It will remain off as long as there is no demand on the secondary side.

# Operation

The unit under control comprises a 2-port valve, variable speed primary pump (single or dual), a plate heat exchanger and a temperature sensor in the secondary flow.

The two port valve opens and closes in line with the secondary demand. As the demand rises, the secondary temperature will start to fall, thus causing the 2-port valve to open and the variable speed pump to ramp up and deliver the increased demand of primary water.

This causes the secondary temperature to rise, closing the two way valve, and slowing down the variable speed pump thus reducing the primary flow. If there is no demand, the two-way valve will shut tight and the pump will shut down via a micro switch on the valve actuator as it closes, maximising energy savings.

The Vari-e-breeze is used as either a stand – alone instantaneous water heater as shown opposite.

Or in conjunction with a buffer vessel to form a semi instantaneous water heater.

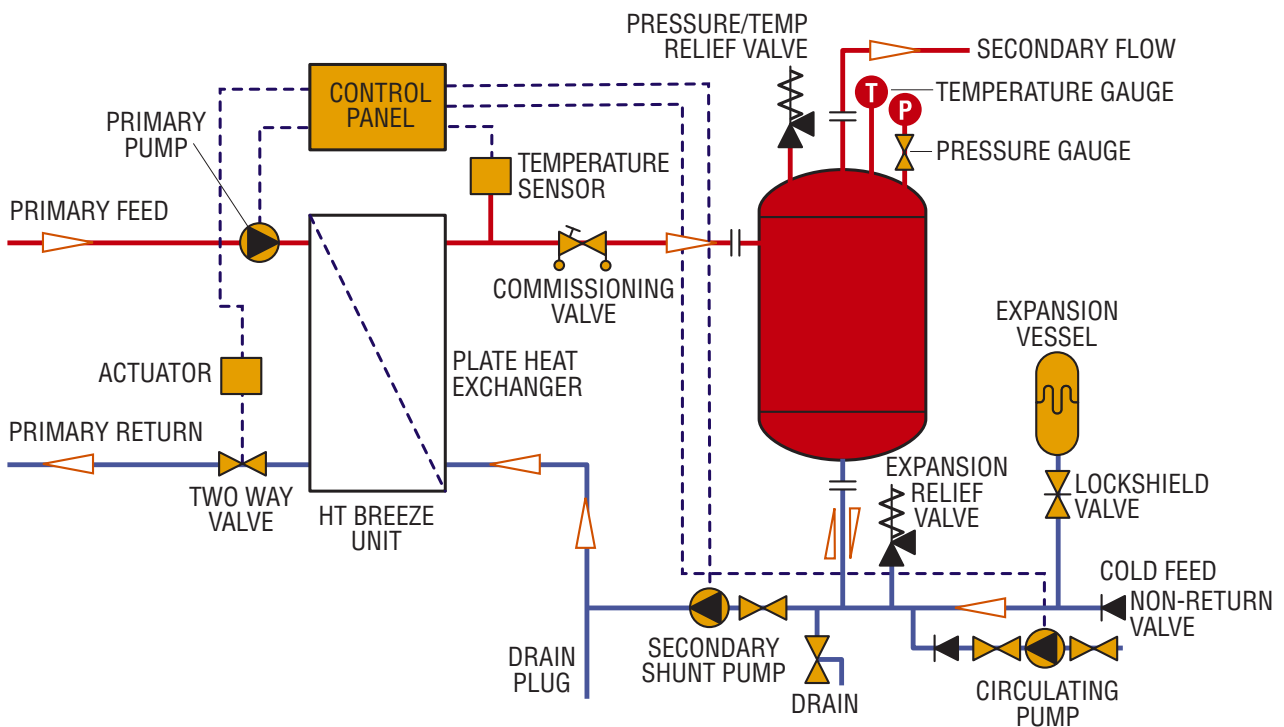
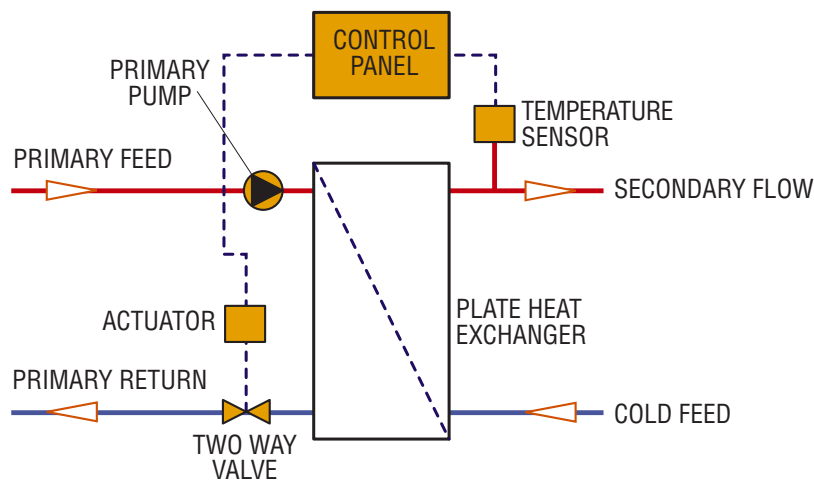

# Sizing and Selection of Stand Alone Vari-E-Breeze.

The Vari-e-breeze can be sized using the same demand factors and worked example shown in the HT-Breeze section (page 4).

Having calculated the total demand units the model required can be selected from the sizing table below.

In the example shown on page 4 a VB250 should be selected.

## Sizing Table

| HT-Breeze Model | Maximum Demand Unit | Max Continuous Duty @ 60°C (litres/sec) | Boiler Power (kw) | Min Secondary Volume (litres) | Electrical Supply |
|-----------------|---------------------|---|-------------------|-------------------------------|-------------------|
| VB - 25         | 15                  | 0.25                                    | 52                | 45                            | 230V / 1P         |
| VB - 50         | 23                  | 0.50                                    | 105               | 75                            | 230V / 1P         |
| VB - 75         | 45                  | 0.75                                    | 157               | 85                            | 230V / 1P         |
| VB - 100        | 70                  | 1.00                                    | 209               | 125                           | 230V / 1P         |
| VB - 125        | 90                  | 1.25                                    | 261               | 135                           | 230V / 1P         |
| VB - 150        | 130                 | 1.50                                    | 313               | 150                           | 230V / 1P         |
| VB - 200        | 210                 | 2.00                                    | 418               | 200                           | 230V / 1P         |
| VB - 250        | 320                 | 2.50                                    | 522               | 250                           | 230V / 1P         |
| VB - 300        | 480                 | 3.00                                    | 672               | 300                           | 400V/3P           |
| VB - 350        | 640                 | 3.50                                    | 732               | 350                           | 400V/3P           |
| VB - 400        | 820                 | 4.00                                    | 836               | 400                           | 400V/3P           |

## Compac Breeze Test Results

The test result graphs represent samples of the general testing and show a 12-hour period using a conventional Plate Heat Exchanger and the equivalent period using a variable speed unit. The exchangers were supplying a total of eight hand basins. Over this time the conventional exchanger primary pump motor used 9 times more energy than the variable speed motor driven a unit.

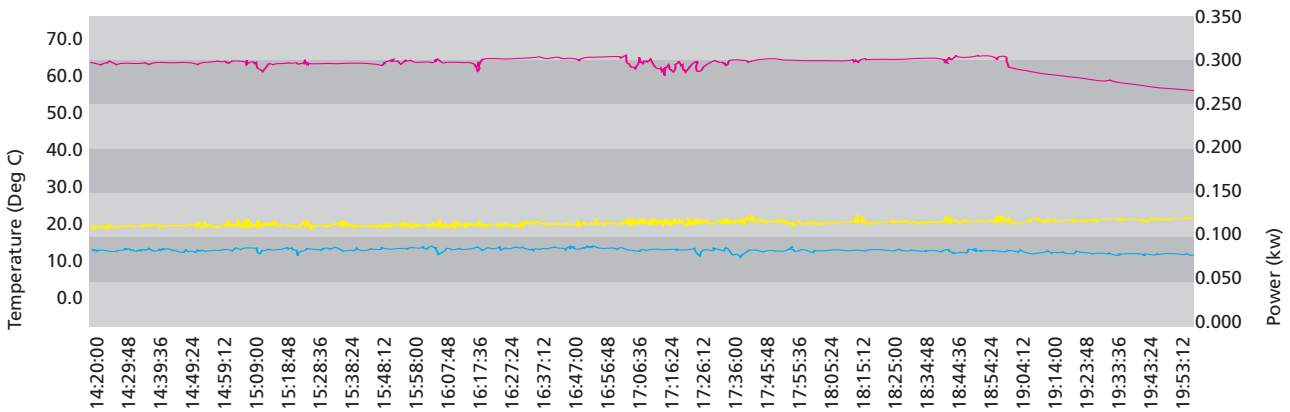

## Variable Speed Unit Test Results

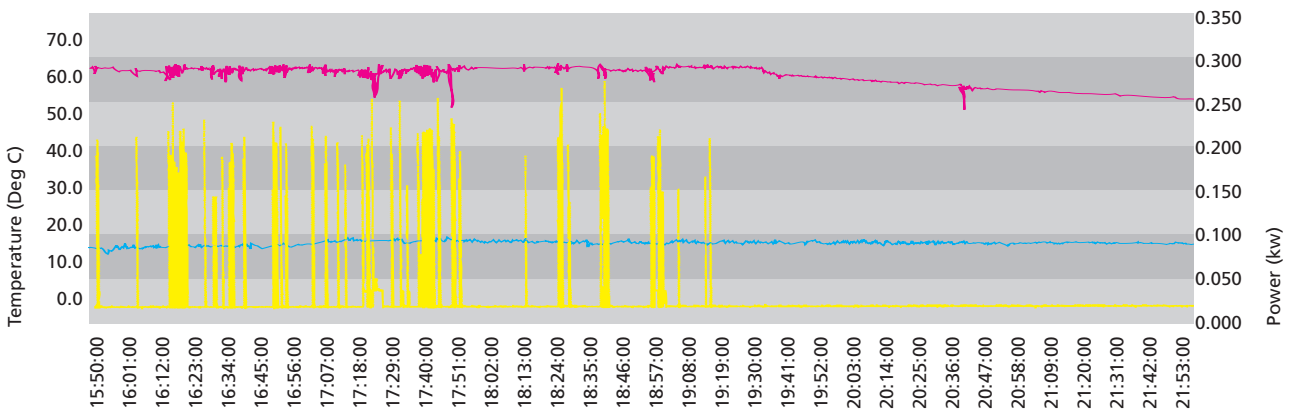

# Vari-E-Breeze general arrangement

## Standalone

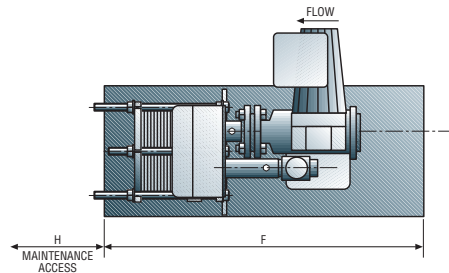
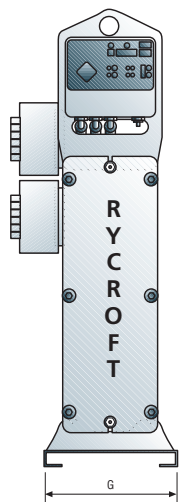
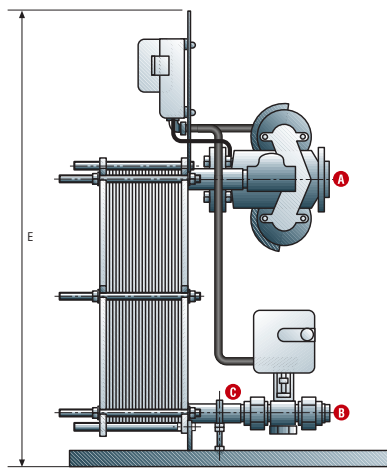

|                      | VB25 TO VB250    | VB300 TO VB400   |
|----------------------|------------------|------------------|
| A Primary Inlet      | DN40 BS4504 PN16 | DN50 BS4504 PN16 |
| B Primary Outlet     | 1-11/2" BSP INT  | 2" BSP INT       |
| C Secondary Inlet    | 1-11/2" BSP EXT  | 2" BSP EXT       |
| D Secondary Outlet   | 1-11/2" BSP INT  | 2" BSP INT       |
| E Overall Height     | 1115             | 1240             |
| F Base Length        | 750              | 750              |
| G Base Width         | 340              | 340              |
| H Maintenance Access | 450              | 550              |

## HT-Breeze and Vari-E-Breeze in conjunction with a buffer vessel

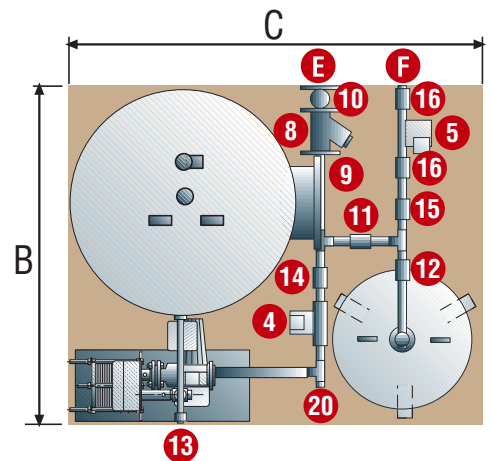
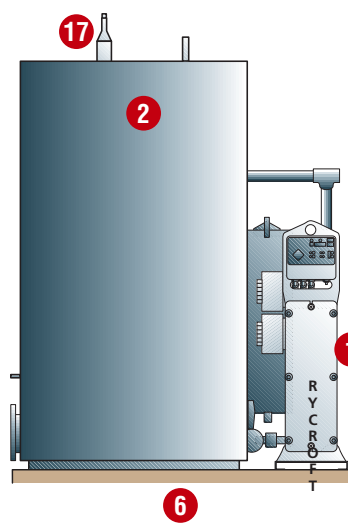
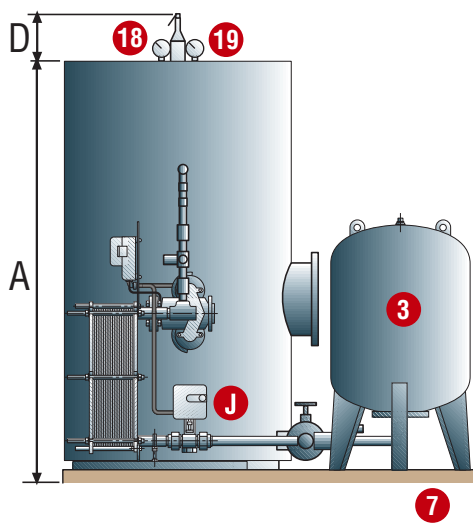

- 1 Packaged PHE
- 2 Buffer Vessel
- 3 Expansion Vessel
- 4 Shunt Pump
- 5 Recirc Pump
- 6 Skid Base
- 7 Pipework
- 8 Cold Feed Strainer
- 9 Cold Feed NRV
- 10 Cold Feed ISO Valve
- 11 Exp Relief Valve
- 12 Exp ISO Valve
- 13 Commissioning Valve
- 14 Shunt Pump ISO Valve
- 15 SEC Return NRV
- 16 SEC Return ISO Valve
- 17 Press Temp Relief Valve
- 18 Pressure Gauge
- 19 Temperature Gauge
- 20 Drain Cock

Pipework comprising of  
 Cold Feed Line                      Secondary Return Line  
 Expansion Line                      Circulation/Shunt Pump Line

| Package | Buffer Cap  | Exp Vess Cap | Stunt Pump | Recirc Pump | Max Dec Vol | Demand     | Peak Flow |
|---------|-------------|--------------|------------|-------------|-------------|------------|-----------|
| VBU-50  | 450 Litres  | 100 Litres   | UPS15-50B  | UPS15-50B   | 600 Litres  | 1797 l/hr  | 1.7 l/s   |
| VBU-100 | 900 Litres  | 200 Litres   | UPS32-55B  | UPS15-50B   | 1200 Litres | 3592 l/hr  | 3.4 l/s   |
| VBU-150 | 1500 Litres | 500 Litres   | UPS40-60B  | UPS15-50B   | 3000 Litres | 5389 l/hr  | 5.5 l/s   |
| VBU-200 | 1700 Litres | 500 Litres   | UPS40-60B  | UPS15-50B   | 3000 Litres | 7186 l/hr  | 6.6 l/s   |
| VBU-250 | 2500 Litres | 750 Litres   | UPS40-60B  | UPS15-50B   | 4500 Litres | 8981 l/hr  | 9.2 l/s   |
| VBU-300 | 3000 Litres | 750 Litres   | UPS50-60B  | UPS25-55B   | 4500 Litres | 10779 l/hr | 11.0 l/s  |

| Package | A    | B    | C    | D   | E   | F  | G   | H  | J  | A                    |
|---------|------|------|------|-----|-----|----|-----|----|----|----------------------|
| VSU-50  | 1915 | 1500 | 1500 | 350 | 40  | 25 | 40  | 40 | 40 | Buffer Vessel Height |
| VSU-100 | 1812 | 1600 | 1800 | 430 | 50  | 25 | 50  | 40 | 40 | Skid Width           |
| VSU-150 | 2762 | 1700 | 1900 | 430 | 65  | 40 | 65  | 40 | 40 | Skid Length          |
| VSU-200 | 2610 | 1700 | 2200 | 430 | 80  | 40 | 80  | 40 | 40 | C                    |
| VSU-250 | 2664 | 1900 | 2500 | 430 | 100 | 50 | 100 | 40 | 40 | D                    |
| VSU-300 | 3060 | 1900 | 2500 | 430 | 100 | 50 | 100 | 50 | 50 | E                    |

# Steam-Breeze Instantaneous Water Heaters

THE INTRODUCTION OF THE STEAM TO WATER VARIANT COMPLETES THE BREEZE RANGE OF INSTANTANEOUS WATER HEATERS.

THE STEAM-BREEZE PROVIDES A PACKAGED UNIT WITH PRIMARY CONTROL AND CONDENSATE SYSTEM, WHICH IS READY TO OPERATE ONCE THE STEAM, WATER AND ELECTRICAL CONNECTION HAVE BEEN MADE.

THERE ARE TWO BASIC MODELS AVAILABLE NAMELY THE DOMESTIC MODEL (10-60 °C) 0.25 TO 5.0 LITRES / SEC, AND THE HEATING MODEL (82-71 °C) 0.5 TO 10.0 LITRES / SEC.

ADDITIONALLY THE UNITS CAN BE PACKAGED WITH EITHER A BUFFER VESSEL, SECONDARY PUMP AND EXPANSION LINE FOR DOMESTIC HOT WATER APPLICATIONS, AND CIRCULATION PUMP, EXPANSION VESSELS AND PRESSURISATION EQUIPMENT FOR HEATING SYSTEMS.

## Default Settings

- Set Temperature
- Number of pumps fitted
- High Temperature cut out (manual reset)
- Low Temperature alarm
- PID settings

## Benefits

- High temperature alarm, indication and cut out and via an independent high limit actuator as standard.
- Isolation and strainer as standard.

- Units designed for 3.8 barg.
- Antivac fitted to prevent system stall.
- Trap fitted as standard, but can be supplied loose to provide head or alternatively a pumping trap set can be supplied where high level pumping is required.

## Fluctuating Steam Demand

Seasonal or operational demands may cause the steam pressure to fluctuate.

Under these circumstances it is important that:-

- a) The steam inlet pressure does not rise above the 3.8 barg max.
- b) Large fluctuation does not cause erratic control.

Under these circumstances it is essential that a pressure reducing valve is fitted.

## Controller Features

- Diagram display of water temperature and set point simultaneously.
- Auto tune facility
- Auto / manual operation.
- Digital display of output power.
- Password protection option.
- Full PID control with low and high cut back.
- Output power limit (high and low).
- Set point limit.

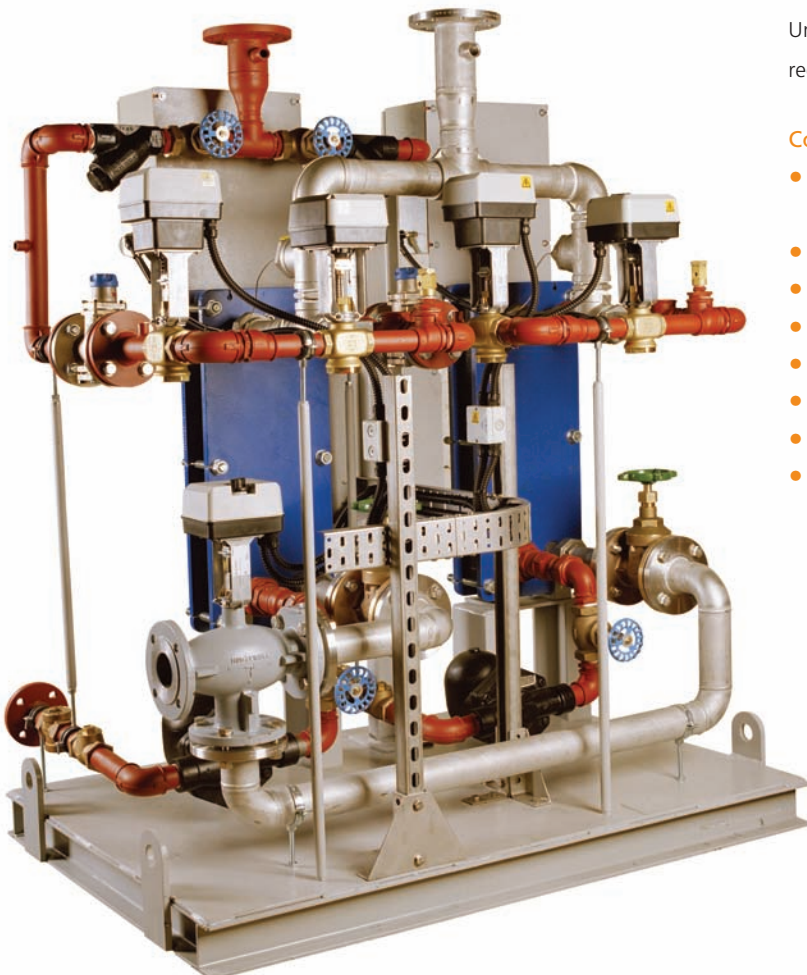



# Operation

The steam compact is a factory tested packaged unit. Once connected to the steam, water and electrical services, it is ready for operation.

The steam compact monitors the secondary water temperature flowing from the exchange outlet passing through the thermocouple.

The temperature controller will compare this temperature with its set point and then correct the difference by adjusting the position of the primary steam control valve.

The high limit stem valve is fully open during normal operation or closed due to occurrence of fault condition.

If the temperature rises above the high limit thermostat set point then the high limit valve will shut the stem off regardless of control valve position.

The fault condition can only be cancelled by manually re-setting the thermostat, allowing the opportunity for investigation.

The high limit valve is failsafe and will close in the event of a power failure.

## For stem pressures up to 3.8 Barg

| Item No: | Name:                        |
|----------|------------------------------|
| 1        | Isolating Valve              |
| 2        | Strainer                     |
| 3        | High Limit Valve             |
|          | High Limit Actuator          |
| 7        | Control Valve                |
|          | Control Valve Actuator       |
| 9        | Vacuum Breaker               |
| 10       | Control Temperature Probe    |
| 11       | High Limit Temperature Probe |
| 12       | Sightglass                   |
| 13       | Non Return Valve             |
| 14       | Steam Trap                   |
| 16       | Isolating Valve              |
| 17       | Plate Heat Exchanger         |
| 18       | Controller                   |
| 23       | Control Panel                |
|          | Pipework                     |

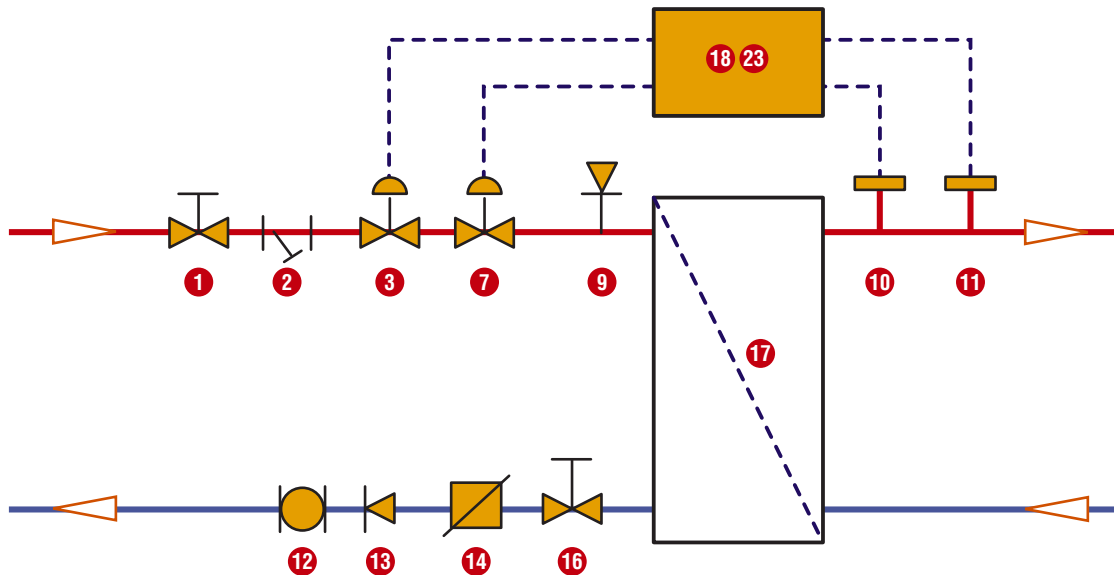



# Equipment Description

The standard steam compact will comprise of the following equipment.

- Primary Steam Isolating Globe Valve
- Steam strainer 100 mesh
- High Limit Valve fitted with an electrical failsafe actuator
- Vacuum breaker
- Supapac gasketed exchanger with stainless steel 316L plates and EPDM gaskets.
- Condensate isolating valves
- Condensate strainer
- Condensate non-return valve
- Condensate sight glass
- Steam Trap

Control panel with temperature controller, secondary circulator overloads, indication and fault lamp, Volt free and BMS contacts.

Temperature sensor, thermocouple type J, installed directly into secondary flow.

High temperature manual reset thermostat

Folded steel base

## Notes

This is given as a guide representative of a typical steam to domestic hot water package.

For larger duties or process applications pneumatic control and high limit valves are used.

A steam trap is fitted as standard, but a pumping trap set can be supplied for non gravity condensate return systems.

## Equipment

- 1 Temperature Probe
- 2 1/2" BSP Compression Fitting (ST ST)
- 3 Sauter High Limit Stat
- 4 32mm Check Valve (GM)
- 5 32mm Isolating Valve (2 Off) (GM)
- 6 UPS40-60B Recirculating Pump

## Stainless Steel Fittings

- 7 1-1/4" Fem/Male Union
- 8 1-1/4" Nipple (4 Off)
- 9 1-1/4" Tee (3 Off)
- 10 1-1/2" To 1-1/4" Reducing Nipple Off
- 11 1-1/4" Socket
- 12 1-1/4" Pipe (2 Off)
- 13 1-1/4" To 1/2" Reducing Bush (2 Off)

## Equipment

- 14 1/2" Vacuum Breaker
- 15 20mm Control Valve
- 16 Control Actuator
- 17 25mm Highlimit Valve
- 18 Highlimit Actuator
- 19 25mm Strainer (2 Off)
- 20 25mm Isolating Valve (2 Off)
- 21 25mm FT14-4.5 Steam Trap
- 22 25mm Check Valve
- 23 25mm Sight Glass

## Steel Fittings

- 24 1-1/4" Fem/Male Union
- 25 1-1/4" Fem/Fem Union
- 26 1" Nipple (8 Off)
- 27 1-1/4" To 1" Reducing Nipple
- 28 1'-3/4" Reducing Nipple (2 Off)
- 29 1" Long Socket
- 30 1" Pipe (3 Off)
- 31 1" x 1" x 1/2" Tee
- 32 1" Tee
- 33 1-1/4" To 1" Eccentric Reducer

## Primary Side Fittings

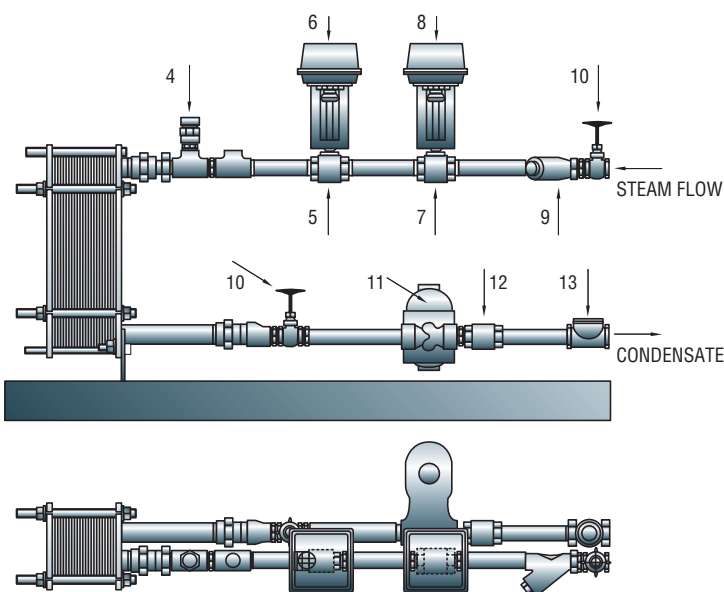

## Secondary Side Fittings

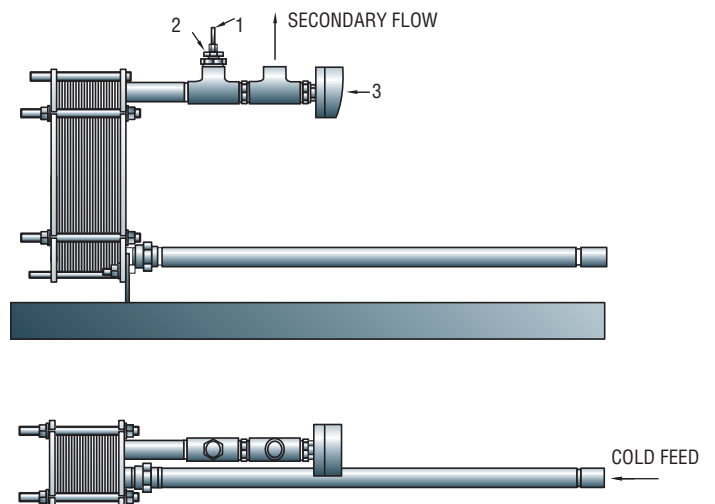

# Sizing and selection of Stand Alone Steam-Breeze

The Steam-Breeze can be sized for domestic hot water application using the same demand factors and worked example shown on the HT-Breeze section (page 4). Having calculated the total demand units, the model required can be selected from the sizing table below. In the example shown on page 4 a SBD: 250 should be selected.

## Steam @ 3.8 Barg to DHW 10/60 DEG C

| Type    | Max Demand Unit | kw   | Sec Flow   | Min Sec Volume |
|---------|-----------------|------|------------|----------------|
| SBD-25  | 15              | 52   | 0.25 l/sec | 45             |
| SBD-50  | 23              | 105  | 0.50 l/sec | 75             |
| SBD-75  | 45              | 157  | 0.75 l/sec | 85             |
| SBD-100 | 70              | 209  | 1.00 l/sec | 125            |
| SBD-125 | 90              | 261  | 1.25 l/sec | 135            |
| SBD-150 | 130             | 313  | 1.50 l/sec | 150            |
| SBD-200 | 210             | 418  | 2.00 l/sec | 195            |
| SBD-250 | 320             | 522  | 2.50 l/sec | 245            |
| SBD-300 | 480             | 627  | 3.00 l/sec | 295            |
| SBD-350 | 640             | 732  | 3.50 l/sec | 345            |
| SBD-400 | 820             | 836  | 4.00 l/sec | 390            |
| SBD-450 | 1050            | 940  | 4.50 l/sec | 440            |
| SBD-500 | 1300            | 1045 | 5.00 l/sec | 490            |

To size the Steam-Breeze for heating applications the kilowatt load should be determined from the system demand and the appropriate heating model selected.

## Steam @ 3.8 Barg to LTHW 71/82 Deg C

| Type     | kw  | Sec Flow    | Min Sec Volume |
|----------|-----|-------------|----------------|
| SBH-50   | 23  | 0.50 l/sec  | 75             |
| SBH-75   | 35  | 0.75 l/sec  | 85             |
| SBH-100  | 46  | 1.00 l/sec  | 125            |
| SBH-125  | 58  | 1.25 l/sec  | 135            |
| SBH-150  | 69  | 1.50 l/sec  | 150            |
| SBH-200  | 92  | 2.00 l/sec  | 195            |
| SBH-250  | 115 | 2.50 l/sec  | 245            |
| SBH-300  | 139 | 3.00 l/sec  | 295            |
| SBH-350  | 161 | 3.50 l/sec  | 345            |
| SBH-400  | 184 | 4.00 l/sec  | 390            |
| SBH-450  | 207 | 4.50 l/sec  | 440            |
| SBH-500  | 230 | 5.00 l/sec  | 490            |
| SBH-600  | 277 | 6.00 l/sec  | 590            |
| SBH-700  | 323 | 7.00 l/sec  | 685            |
| SBH-800  | 369 | 8.00 l/sec  | 785            |
| SBH-900  | 415 | 9.00 l/sec  | 880            |
| SBH-1000 | 461 | 10.00 l/sec | 980            |

